



**SACCARDO**<sup>®</sup>



**SBE**

ELECTRO-SPINDLES  
FOR CUTTING AND MILLING  
AIR COOLING

电主轴  
用于切削和铣削  
空气冷却



MADE IN  
ITALY



**PROCESSING:** Cutting and edging  
**用途:** 切割和镶边

**IDEAL FOR:** Wood, Stone  
**行业:** 木工、石材

## Technical features

技术特点

# EASYSPIN



“Easyspin”

“EASYSPIN” double-thread insert to be settled to the shaft, becoming an integral part of it.

This will allow the use of both tool threads (right or left).

Thread uniformity will give the following advantages:

- Easier marker tools finding
- More flexible and lower costing tools warehouse
- Electro-spindles stock reduction
- Both clockwise and counterclockwise electro-spindle rotation directions possible

Easier and cheaper electro-spindle maintenance as it will no longer be necessary to replace the full shaft but just the insert.

The replacement can be done directly by the final customer, without removing the electro-spindle from the machine and without calling an external technician. The resulting machine downtime will be reduced.

“EASYSPIN” 双螺纹嵌件将固定在轴上，是整套刀具其不可或缺的一部分。

可使用两种螺纹的刀具（右旋或左旋）。

统一螺纹标准将具有以下优点：

- 更方便找到刀具
- 更灵活，刀具库成本更低
- 减少电主轴库存
- 电主轴可顺时针和逆时针旋转

由于不再需要更换整个轴，而只需更换嵌件，因此电主轴维护更方便、成本更低。

终端客户可直接进行更换，而无需从机器上卸下电主轴，也无需致电外部技术人员。因此可减少停机时间。

The maximum rotation speed that can be reached using a frequency variators is:  
使用变频器可达到的最大转速为：

Only disk  
仅有盘片

SBE 93	4.500 rpm
SBE 107	4.500 rpm
SBE 127	3.800 rpm

Disk + 1/2" GAS tool fitting  
盘片 + 1/2" GAS刀具配件

SBE 93 M	6.000 rpm
SBE 107 M	6.000 rpm
SBE 127 M	6.000 rpm

## Terminal box position

接线盒位置

The terminal boxes are arranged for the cable passing-through in compliance with the EN 62444-10 standard.  
布置用于电缆通过的接线盒符合EN 62444-10标准。

SBE/SBE 93 M	1 hole / 1孔	M25 x 1,5	SBE/SBE 107 M	1 hole / 1孔	M25 x 1,5	SBE/SBE 127 M	2 holes / 2孔	M32 x 1,5
--------------	-------------	-----------	---------------	-------------	-----------	---------------	--------------	-----------

## Protection degree

防护等级

IP 66

6 Totally protected against dust  
百分百防止、防水

6 Protected against powerful water jets from any direction  
防护任何方向的强水流喷射



The manufacturer is responsible for the correct evaluation of the protection degree necessary for his application and for using the appropriate protections.

制造商有责任正确评估其应用所需的防护等级，并采用适当的防护措施。



Do not use a high-pressure water washing-machine.

请勿使用高压水流清洗机器。

## Tools recommended dimensions and suggested rotations per minute

推荐刀具尺寸和建议每分钟转数

	[ø mm]	[ø mm]	Marbles 大理石 [40/50 m/s]	Sandstones 砂岩 [55/65 m/s]	Graniti Duri 硬质花岗岩 [25/30 m/s]	Soft granites 软质花岗岩 [32/40 m/s]
SBE/SBE 93 M	185,5	600	1.300/1.600	1.750/2.050	800/950	1.000/1.300
SBE/SBE 107 M	213,5	750	1.000/1.300	1.400/1.650	640/750	815/1.000
SBE/SBE 127 M	253,5	900	850/1.050	1.150/1.400	530/640	680/850



Adequate protection guards are strongly recommended.

强烈建议采用充分的防护措施。



# Overall and fitting dimensions

总尺寸和装配尺寸

M

Electro-spindle with blade-holding flanges and clamping nut, with front 1/2" GAS tool connection, hollow shaft for water passage and rear rotating joint (not included) predisposition with maximum speed 6,000 rpm

带叶片固定法兰和夹紧螺母的电主轴，配有正面1/2" GAS刀具连接、通水空心轴、后部旋转接头（未包括在内），最高转速为6,000转/分

## 93 · M

	L1	L2	L3	L4
M	584	501	460	604
L	624	541	500	644

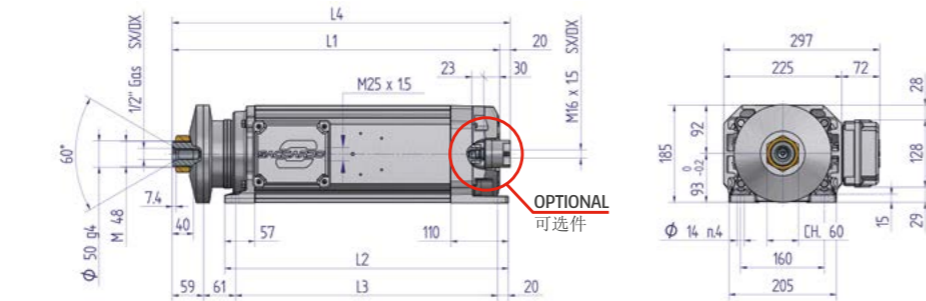

## 107 · M

	L1	L2	L3	L4
C	643	519	477	676
M	691	567	525	724
L	791	667	625	824

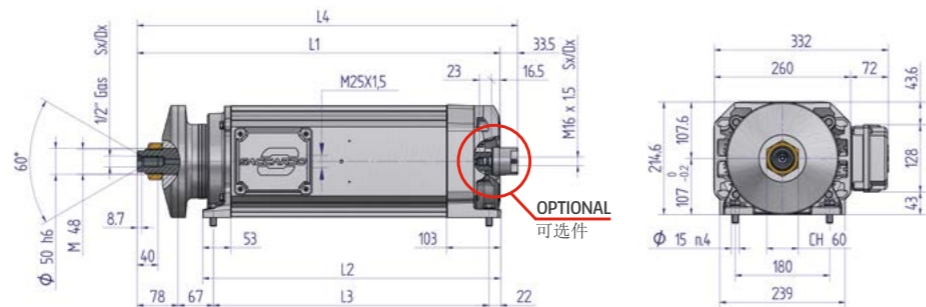

## 127 · M

	L1	L2	L3	L4
C	691	537	477	725
M	748	594	534	782
L	868	714	654	902

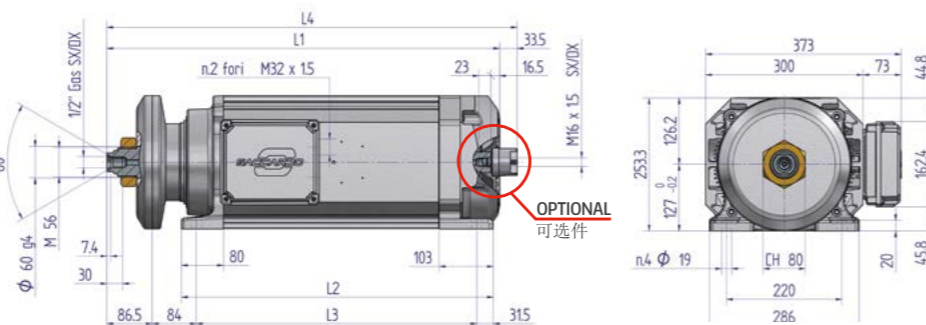

# 400 V / 50 Hz Rated data

额定转速

Size	Dimensions	S1 Duty - Rated Values				S6 - 60% Duty - Rated Values				Weight (kg)
		Power		Current	Speed	Power		Current	Speed	
		(kW)	(CV)	(A)	(rpm)	(kW)	(CV)	(A)	(rpm)	
93 A/2	M	5,6	7,5	11,9	2.870	6,6	9,1	14,3	2.850	50
93 B/2	M	8	10,9	17	2.880	9,5	12,8	20,3	2.860	69
93 C/2	L	10	13,6	21,2	2.890	11,8	16	25	2.870	65
93 D/2	L	11,2	15,2	23,6	2.900	12,5	17	26,8	2.880	71
107 A/2	C	11,2	15,2	20,5	2.880	12,5	17	26,7	2.865	62
107 B/2	C	13,2	18	25	2.880	15,9	21,6	30,5	2.865	70
107 C/2	C	15	20,4	28,2	2.890	18	24,3	33,5	2.865	78
107 D/2	M	18	24,5	33,8	2.890	21,2	28,5	39,3	2.870	95
107 LA/2	L	22	30	41,6	2.900	26,5	36	49,2	2.870	103
127 A/2	C	19	26	35,5	2.880	22	30	40,7	2.865	135
127 B/2	C	23,5	32	43,5	2.880	28	38	51,7	2.865	140
127 C/2	C	28	38	51,5	2.900	33	45	61	2.865	145
127 D/2	M	30	41	55,5	2.900	36	48	65	2.870	150
127 LA/2	L	35,5	48	65	2.900	42,5	57,5	77	2.870	159
93 A/4	M	4,7	6,5	10,6	1.420	5,5	7,5	12,4	1.400	41
93 B/4	M	5,3	7,2	11,7	1.420	6,3	8,5	14	1.400	50
93 BB/4	M	6,3	8,6	13,7	1.425	7,5	10	16,5	1.405	56
93 C/4	L	9	12,2	19	1.425	11	15	23,5	1.405	63
93 D/4	L	10	13,6	21,2	1.425	11,8	16	25	1.405	71
107 B/4	C	9,5	12,9	20,3	1.425	11	15	24	1.405	84
107 C/4	C	11	15,2	24,2	1.430	13	17,5	28,5	1.410	88
107 D/4	M	13	17,5	28,4	1.430	15,5	21	34,5	1.410	97
107 E/4	M	14,6	20	30	1.430	16,5	22,5	36,8	1.420	102
107 LA/4	L	17	23,1	36,2	1.435	20	27	43,5	1.420	111
107 LBJ/4	L	20	27,5	43	1.435	23,5	32	48,5	1.420	129
127 A/4	C	16	22	34,3	1.445	19	26	40,6	1.420	129
127 B/4	C	20	27,5	42,1	1.445	23	31	49,5	1.420	134
127 C/4	M	22	30,5	47,5	1.445	26,5	36	55,6	1.420	141
127 D/4	M	24	33	53	1.455	29,5	40	61,5	1.430	148
127 LA/4	L	30	40	67	1.455	37,5	51	78	1.430	169
107 A/6	C	5,6	7,6	13,5	960	6,5	8,8	15,8	940	91
107 B/6	M	8,5	11,6	20,5	960	10	13,5	24,3	940	100
107 LA/6	L	11,8	16	28,5	965	13,5	18,3	32,5	945	116
127 A/6	M	14,6	20	29,5	960	17,5	23,5	38,5	945	123
127 B/6	M	18	24,5	40	965	21,5	29	46,5	950	143
127 LA/6	L	24	33	53	965	28,5	38,5	61	950	169
127 A/8	M	11	15	29	715	12,5	17	33	705	148
127 LA/8	L	15	20,5	40	720	17,5	23,8	45	710	169

S1 (Continuous service): Operation under a constant load with a duty cycle which allows to reach the thermal balance.  
 S6 (Uninterrupted periodical service): Operation including a series of identical cycles, each of them made up of a constant load operation period and a load less operation period. There are not resting periods. The processing period does not allow the thermal balance to be reached.

S1 (连续工作)：在恒定负载下运行，占空比可达到热平衡。  
 S6 (不间断定期工作)：运行包括一系列相同循环，每个循环均由恒定负载运行时间段和无载运行时间段组成。不存在休息时间。加工期间不允许达到热平衡。

More electrical details are available on demand

可按需提供更多电气详情



**SACCARDO ELETTROMECCANICA S.r.l.u.**

地址: Via Casa Celeste, 10

36014 Santorso (VI) - ITALY

T. / 电话: +39 0445 540542 - F. / 传真: +39 0445 540538

VAT Code / 增值税号: IT00899480248

www.saccardo.it - info@saccardo.it

**中国总代理**

**安德鲁信重工江苏有限公司**

地址: 江苏省江阴市澄江东路3号手机:

18961619099

邮箱: info@andrewen.com

网址: www.andrewen.com

